

Operating Instructions Air Conditioner



Wall Mounted (Type K2)

* Shows type 45, 56, 73, 106

Model No.

INDOOR UNIT

Wall Mounted (Type K2)

S-15MK2E5B	S-45MK2E5B
S-22MK2E5B	S-56MK2E5B
S-28MK2E5B	S-73MK2E5B
S-36MK2E5B	S-106MK2E5B

- Connectable outdoor unit lineup

OUTDOOR UNIT

Refrigerant type : R410A
mini VRF (Type LE1, LE2)
2WAY VRF (Type ME2)
3WAY VRF (Type MF3)

Refrigerant type : R32
mini VRF (Type LZ2)



ENGLISH

Before operating the unit, read these operating instructions thoroughly and keep them for future reference.





Thank you for purchasing this Panasonic product.
 This product is a commercial air conditioner indoor unit.
 Installation Instructions attached.

Contents

- Safety Precautions 2
- Precautions for Use 6
- Names of Parts 7

- Maintenance 8
 - Operation Mechanism 9
- Troubleshooting 10
 - Before Requesting Services 11

- Specifications 13
 - Indoor unit 13
 - Outdoor unit 14

	WARNING	This symbol shows that this equipment uses a flammable refrigerant. If the refrigerant is leaked, together with an external ignition source, there is a possibility of ignition.
	CAUTION	This symbol shows that a service personnel should be handling this equipment with reference to the Technical Manual.
	CAUTION	This symbol shows that there is information included in the Operating Instructions and/or Installation Instructions.

Product Information

If you have problems or questions concerning your Air Conditioner, you will need the following information. Model and serial numbers are on the nameplate.

Model No. _____

Serial No. _____

Date of purchase _____

Dealer's address _____

Phone number _____





Important Information Regarding The Refrigerant Used

NOTE

Refer to the Installation Instructions attached to the outdoor unit.

Safety Precautions

The following symbols used in this manual, alert you to potentially dangerous conditions to users, service personnel or the appliance:

	WARNING	This symbol refers to a hazard or unsafe practice which can result in severe personal injury or death.
	CAUTION	This symbol refers to a hazard or unsafe practice which can result in personal injury or product or property damage.
	Prohibited matters	
	Matters to be observed	

- Read these Operating Instructions carefully before using this air conditioner. If you still have any difficulties or problems, consult your dealer for help.
- This air conditioner is designed to give you comfortable room conditions. Use this only for its intended purpose as described in these Operating Instructions.

! WARNING



Confirm to authorized dealer or specialist on usage of specified refrigerant type. Using of refrigerant other than the specified type may cause product damage, burst and injury etc.

This air conditioner has no ventilator for intaking fresh air from outdoors. You must open doors or windows frequently when you use gas or oil heating appliances in the same room, which consume a lot of oxygen from the air. Otherwise there is a risk of suffocation in an extreme case.



Never use or store gasoline or other flammable vapor or liquid near the air conditioner — it is very dangerous.

Do not use this appliance in a potentially explosive atmosphere.

Never touch the unit with wet hands.

Do not insert your fingers or other objects into the air conditioner indoor or outdoor unit, rotating parts may cause injury. 

WARNING



If the refrigerant comes in contact with a flame, it produces a toxic gas.

For safety, be sure to turn the air conditioner off and also to disconnect the power before cleaning or servicing.

Pull off the power plug from a receptacle, or switch off the breaker, or switch off the power disconnecting mean to isolate the air conditioner from the main power supply in case of emergency.



Dispose of according to national and/or local legislation.



This product must not be modified or disassembled under any circumstances.

Modified or disassembled unit may cause fire, electric shock or injury.

Do not clean inside the indoor and outdoor units by users. Engage authorized dealer or specialist for cleaning.

In case of malfunction of this appliance, do not repair by yourself. Contact the sales dealer or service dealer for a repair and disposal.



Provide a power outlet to be used exclusively for each unit, and a power supply disconnect, Earth Leakage Circuit Breaker (ELCB) or Residual Current Device (RCD) for overcurrent protection should be provided in the exclusive line.

Provide a power outlet exclusively for each unit, and full disconnection means having a contact separation in all poles must be incorporated in the fixed wiring in accordance with the wiring rules.

To prevent possible hazards from insulation failure, the unit must be grounded.



Do not use modified cord, joint cord, extension cord or unspecified cord to prevent overheating and fire.



The appliance shall be stored in a room without continuously operating ignition sources (for example: open flames, an operating gas appliance or an operating electric heater).

Be aware that refrigerants may not contain an odour.

An unventilated area where the appliance using flammable refrigerants is installed shall be so constructed that should any refrigerant leak, it will not stagnate so as to create a fire or explosion hazard.

The appliance shall be stored in a well-ventilated area where the room size corresponds to the room area as specified for operation.

After the unit is installed, never fail to ask the installer for the floor space of the room where the unit is installed and the refrigerant charge amount.

In case the unit or the room divider is changed, never fail to consult the sales dealer or service dealer.





Do not use means to accelerate the defrosting process or to clean, other than those recommended by the manufacturer.

Do not pierce or burn.

In cases that require mechanical ventilation, ventilation openings shall be kept clear of obstruction.

WARNING



 The appliance shall be stored in a room without continuously operating open flames (for example: an operating gas appliance) and ignition sources (for example: an operating electric heater).

 Stop using the product when any abnormality/failure occurs and disconnect the power plug or turn off the power switch and breaker. (Risk of smoke/fire/electric shock)
Examples of abnormality/failure:

- The ELCB trips frequently.
- The product sometimes does not start when turned on.
- The power is sometimes disconnected when the cord is moved.
- Burnt odor or abnormal noise is detected during operation.
- The body is deformed or abnormally hot.
- Water leaks from the indoor unit.
- Power cord or plug becomes abnormally hot.
- Fan speed cannot be controlled.
- The unit stops running immediately even if it is switched on for operation.

Contact immediately your local dealer for maintenance/repair.

 When the optional 'R32 refrigerant leakage detection sensor' detects refrigerant leakage, P08 alarm and inspection mark will be displayed on the remote controller, the indoor unit fan will be running to prevent refrigerant stagnation, and it will not stop even if you press the ON/OFF operation button on remote controller. In such a case, do not turn off the ELCB, ventilate the room, and contact the service dealer immediately. Also, do not use combustion equipment such as stoves.

 Do not sit or step on the unit.  You may fall down accidentally.

 If refrigerant R32 is used and R32 refrigerant leakage detection sensor is connected to the indoor unit, do not turn off the ELCB of the indoor unit except when there is a symptom of abnormality or failure, or when performing short-term maintenance. (When the ELCB is turned off, R32 refrigerant leakage detection sensor cannot detect the refrigerant leakage when the refrigerant leaks, and it may lead to cause the generation of toxic gas and fire.)

Do not use the following items near the indoor unit and R32 refrigerant leakage detection sensor as they may cause fire or false detection of refrigerant leakage.

- Gas equipment that uses flammable gas (propane, methane, etc.)
- Combustible gas such as pesticides and hair spray (LPG, etc.)
- Sprays, drugs, chemicals, paints, etc. that use siloxane.

WARNING



If the alarm display J01 appears, there is something wrong R32 refrigerant leakage detection sensor or its wiring connection to the indoor unit.

Contact the service dealer immediately.

(It may not be detected when the refrigerant leaks.)

When the alarm display J02 appears, it is the end of the life of the sensor board of R32 refrigerant leakage detection sensor.

Contact the service dealer as soon as possible to replace the sensor board.

(If the sensor board is used as it is without being replaced, the sensor may be deteriorated and the refrigerant leakage may not be detected properly.)

CAUTION



This appliance is intended to be used by expert or trained users in shops, in light industry and on farms, or for commercial use by lay persons.

This appliance can be used by children aged from 8 years and above and persons with reduced physical, sensory or mental capabilities or lack of experience and knowledge if they have been given supervision or instruction concerning use of the appliance in a safe way and understand the hazards involved. Children shall not play with the appliance. Cleaning and user maintenance shall not be made by children without supervision.

Keep the fire alarm and the air outlet at least 1.5 m away from the unit.

Do not cool or heat the room too much if babies or invalids are present.



Do not turn the air conditioner on and off from the power mains switch. Use the ON/OFF operation button.

Do not stick anything into the air outlet of the outdoor unit. This is dangerous because the fan is rotating at high speed.



Do not touch the air inlet or the sharp aluminum fins of the outdoor unit. You may get injured.



Do not stick any object into the FAN CASE. You may be injured and the unit may be damaged.



Do not touch the fan because it automatically rotates when it detects a refrigerant leak. You may be injured.

NOTICE

- The appliance shall be stored so as to prevent mechanical damage from occurring.
- The compressor may occasionally stop during thunderstorms. This is not a mechanical failure. The unit automatically recovers after a few minutes.
- The English text is the original instructions. Other languages are translation of the original instructions.

Precautions for Use

Installation

- This air conditioner must be installed properly by qualified installation technicians in accordance with the Installation Instructions provided with the unit.
- Before installation, check that the voltage of the electric supply in your home or office is the same as the voltage shown on the nameplate.

WARNING

Avoid the following locations for installation.

- Locations where smoke or combustible gas exists. Also locations of extremely high temperature such as a greenhouse.
- Locations where excessively high heat-generating objects are placed.

Attention:

- Avoid installing the outdoor unit where salty sea water can splash directly onto it or in sulphurous air near a spa. (To protect the air conditioner from heavy corrosion)

Wiring

- All wiring must conform to the local electrical codes. (Consult your dealer or a qualified electrician for details.)
- Each unit must be properly grounded with a ground (or earth) wire or through the supply wiring.
- Wiring must be done by a qualified electrician.

Operation Preparation

Turn the power mains on 5 hours before the start of operation.

(For warm-up)

- Leave the power mains ON for continuous use.

NOTE

Pull off the power plug from a receptacle, or switch off the breaker, or switch off the power disconnecting mean to isolate the air conditioner from the main power supply when not in use for a long time.

Tips for Energy Saving

■ Avoid

- **Do not block the air intake and outlet of the unit. (If either is obstructed, the unit will not function well, causing malfunction.)**
- During cooling operation, use sunshades, blinds or curtains to prevent direct sunlight from entering the room.

■ Do

- Always keep the air filter clean. (A clogged filter will impair the performance of the unit.) → "Maintenance" (P.8)
- To prevent conditioned air from escaping, keep windows, doors and any other openings closed.

Information for Users on Collection and Disposal of Old Equipment and Used Batteries



These symbols on the products, packaging, and/or accompanying documents mean that used electrical and electronic products and batteries should not be mixed with general household waste.

For proper treatment, recovery and recycling of old products and used batteries, please take them to applicable collection points, in accordance with your national legislation and the Directives 2002/96/EC and 2006/66/EC. By disposing of these products and batteries correctly, you will help to save valuable resources and prevent any potential negative effects on human health and the environment which could otherwise arise from inappropriate waste handling.

For more information about collection and recycling of old products and batteries, please contact your local municipality, your waste disposal service or the point of sale where you purchased the items.

Penalties may be applicable for incorrect disposal of this waste, in accordance with national legislation.

For business users in the European Union

If you wish to discard electrical and electronic equipment, please contact your dealer or supplier for further information.

[Information on Disposal in other Countries outside the European Union]

These symbols are only valid in the European Union. If you wish to discard these items, please contact your local authorities or dealer and ask for the correct method of disposal.



Note for the battery symbol (bottom two symbol examples):

This symbol might be used in combination with a chemical symbol. In this case it complies with the requirement set by the Directive for the chemical involved.



Names of Parts

INDOOR UNIT

Type 15, 22, 28, 36

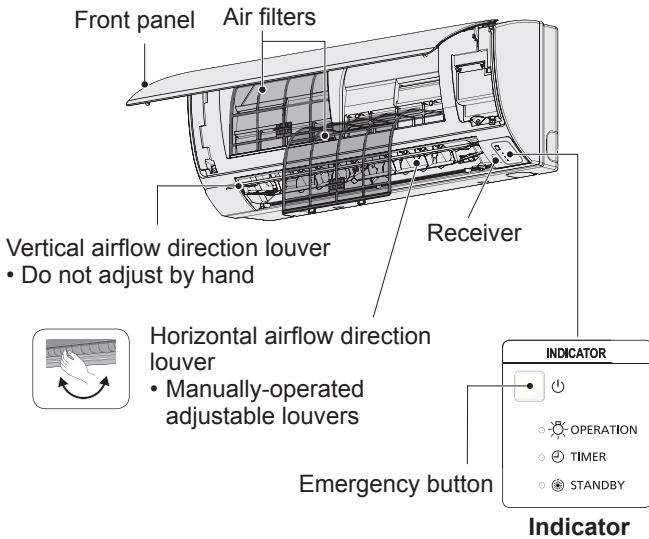

Type 45, 56, 73, 106

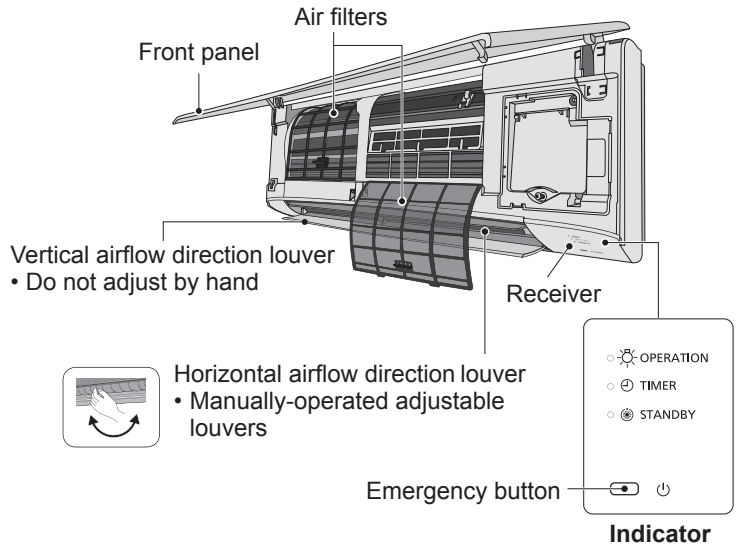

OUTDOOR UNIT

mini VRF (Type LZ2)

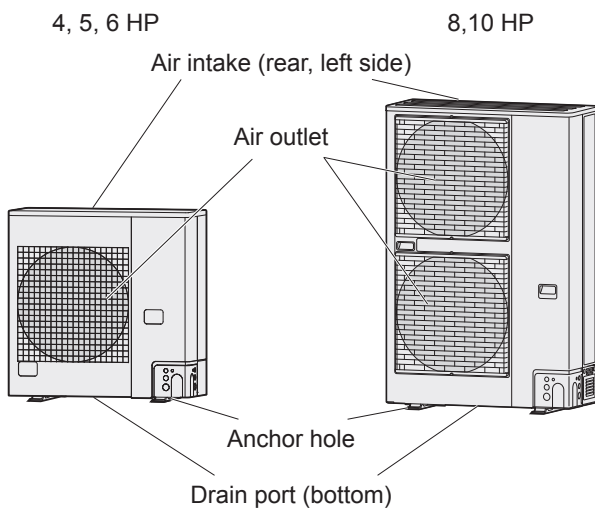

mini VRF (Type LE1, LE2) 2WAY VRF (Type ME2) 3WAY VRF (Type MF3)

NOTE

Refer to the Operating Instructions attached to the outdoor unit.

Optional

Wireless Remote Controller



Model No. CZ-RWS3
The receiver :
Model No. CZ-RWRC3
(For all indoor units)

(Infrared Remote Controller)

Timer Remote Controller



Model No. CZ-RTC4
For all indoor units

High-spec Wired Remote Controller



Model No. CZ-RTC5B
For all indoor units

Wired Remote Controller

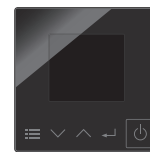

Model No. CZ-RTC6*
For all indoor units

Read the Operating Instructions included with the Remote Controller.

■ Operation & Adjusting Airflow Direction

Refer to the Operating Instructions attached to the Remote Controller.

* The flap display on the remote controller differs from the actual flap angle.

Maintenance

⚠ WARNING

- For safety, be sure to turn the air conditioner off and disconnect the power before cleaning. (Otherwise, electric shock or injury may result because the fan is rotating at high speed.)
- Do not pour water on the indoor unit. (This may damage the internal components and cause an electric shock hazard.)

⚠ CAUTION

- Never use solvents or harsh chemicals. Also, do not wipe plastic parts using very hot water. (This may cause deformation or change in colour.)
- Some metal edges and fins are sharp. Be careful when you clean those parts. (Injury may result.)
- Use a firm stool or ladder when cleaning an indoor unit installed in high locations.

- The internal coil and other components of the outdoor unit must be cleaned periodically.
 - Consult your dealer or service center.

■ Air Filter Maintenance

It is recommended that the air filter be cleaned when the  (Filter) appears on the display. Clean the filter frequently for best performance in the area of dusty or oil spots regardless of filter status.

Timer Remote Controller

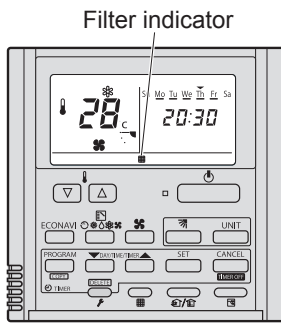

High-spec Wired Remote Controller

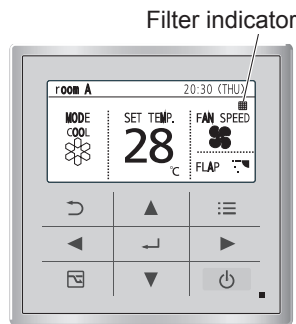

Wired Remote Controller



■ How to remove

Type 15, 22, 28, 36

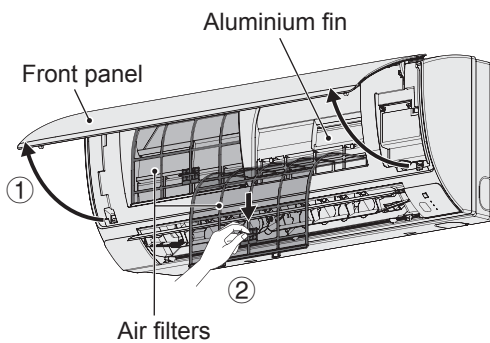

Type 45, 56, 73, 106

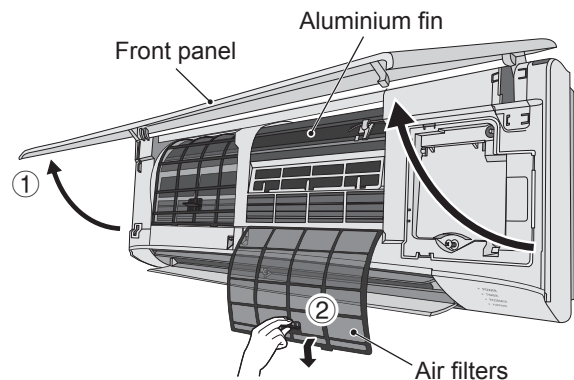

■ Cleaning

Cleaning instructions :

- Do not use benzene, thinner or scouring powder.
- Use only soap (≈pH7) or neutral household detergent.
- Do not use water hotter than 40°C.

Indoor unit :

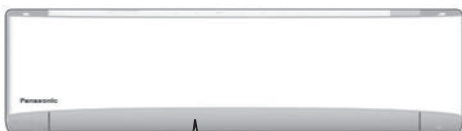

Wipe with a soft cloth.
(If it is very dirty, use a cloth moistened with water.)

Air filters :

- Air filters cleaning is needed every two weeks.
- Wash/rinse the filters gently with water to avoid damage to the filter surface.
- Dry the filters thoroughly under the shade, away from fire or direct sunlight.
- Replace any damage filter.

NOTE

- Clean the filter regularly for best performance and to reduce power consumption.
- Please consult your nearest dealer for seasonal inspection.

■ After Cleaning

1. After the air filter is cleaned, reinstall it in its original position.
Be sure to reinstall in reverse order.
2. [In the case of Timer Remote Controller]
Press the Filter reset button.
The  (Filter) indicator on the display goes out.



[In the case of High-spec Wired Remote Controller]
Refer to the Operating Instructions attached to the optional High-spec Wired Remote Controller.

Operation Mechanism

■ Heating performance

- This air conditioner utilizes outside air for heating; its heating performance reduces as outside temperature decreases.
→ In the event that heating is not sufficient, please use an additional heating appliance.

■ Defrosting

- This appliance may start defrosting operation to melt frost formed in the outdoor unit.
 - ① **Defrosting starts:** The indoor unit fan stops (or the speed becomes extremely slow).
→ “” (STANDBY) appears.
 - ② **Heating operation resumes after several minutes:** The indoor unit fan remains stopped (or it will run at a very slow speed) until the indoor heat exchanger coil warms up sufficiently.
→ “” (STANDBY) appears.
 - ③ **Defrosting is complete:** The indoor unit fan starts operation.
→ “” (STANDBY) disappears.

■ “DRY” operation

- Once the room temperature reaches the level that was set, the outdoor unit repeats the cycle of turning on and off automatically.
- When the room temperature is more likely to reach the level that was set, the fan speed is set to “breeze” (light wind) automatically.

■ Should power failure occur while the unit is running

The unit will resume operation automatically. Operation settings prior to power failure will be used.

Troubleshooting

Check before consulting or requesting services.

Symptom		Cause / Action	
Indoor unit	Noise	Sound like streaming water is heard during operation or after operation.	<ul style="list-style-type: none"> • Sound of refrigerant liquid flowing inside unit • Sound of drainage water through drain pipe
		Cracking noise is heard during operation or when operation stops.	<ul style="list-style-type: none"> • Sound due to temperature changes of parts
	Discharged air smells during operation.		<ul style="list-style-type: none"> • Indoor odor components, cigarette odor and cosmetic odor accumulated in the air conditioner and its air is discharged. • The unit inside is dirty. (Contact your dealer.)
	Dewdrops accumulate near the air outlet during cooling operation.		<ul style="list-style-type: none"> • Internal moisture is cooled by cool wind and accumulates as dewdrops.
	Fog occurs during cooling operation.		<ul style="list-style-type: none"> • If the air conditioner has been installed at places such as restaurants where large amounts of oil mist exist, cleaning is necessary because the unit inside (heat exchanger) is dirty. (Contact your dealer.)
	Fog occurs during heating operation.		<ul style="list-style-type: none"> • Defrost operation is in process.
	The fan is rotating for a while even though operation stops.		<ul style="list-style-type: none"> • Fan rotation makes operation smooth. • The fan may rotate to dry the heat exchanger depending on the setting.
	The indoor unit fan is running and does not stop when ON/OFF operation button on remote controller is pressed.		<ul style="list-style-type: none"> • The refrigerant may be leaking. If R32 refrigerant leakage detection sensor is connected and the refrigerant leaks, P08 alarm and inspection mark will be displayed on the remote controller and the fan will automatically operate. Please ventilate the room without turning off the earth leakage circuit breaker and contact the service dealer for assistance. • Are you using gas equipment (propane, butane, methane, etc.) and sprays near R32 refrigerant leakage detection sensor? R32 refrigerant leakage detection sensor could lead to false detection and the fan may start rotating. Please contact the service dealer for assistance.
	Airflow direction	Airflow direction changes while operating. Airflow direction cannot be set. Airflow direction cannot be changed.	<ul style="list-style-type: none"> • When air discharge temperature is low during heating operation, or during defrost operation, horizontal wind flow is made automatically.
		The flap moves several times after the direction is changed.	<ul style="list-style-type: none"> • The flap moves to the standard position once, and then turns to the set airflow direction.
	Dust is discharged.		<ul style="list-style-type: none"> • Dust accumulated inside the indoor unit is discharged.
	At the initial high-speed operation, the fan sometimes rotates faster than the setting speed. (3 to 30 minutes)		<ul style="list-style-type: none"> • This is for operation check in order to confirm whether the fan motor rotation is within the range of use.

Symptom		Cause / Action
Outdoor unit	No operation (When the power is turned on immediately / When operation is stopped and resumed immediately)	• Operation is not activated for the first approx. 3 minutes because the compressor protection circuit is activated.
	Noise occurs during heating operation.	• Defrost operation is in process.
	Steam comes out during heating operation.	
	The fan continues to rotate even after the operation is stopped using the remote controller.	• This is for smooth operation.

Before Requesting Services

Symptom	Cause	Action
The air conditioner does not operate although the power is turned on.	Power failure or after power failure	Press the power ON/OFF button on the remote controller.
	The operation (power) button is turned off.	• If the breaker is turned off, turn the power on. • If the breaker has been tripped, consult your dealer without turning it on.
	Fuse blow out.	Contact your dealer.
Poor cooling or heating performance	The air intake or air outlet of indoor and outdoor units is clogged with dust.	Remove the dust.
	The fan speed switch is set to "Low".*	Change to "Medium" or "High".*
	Improper temperature settings	See "Tips for Energy Saving". (P.6)
	The room is exposed to direct sunlight in cooling mode.	
	Doors or windows are open.	See "Maintenance". (P.8)
	The air filter is clogged.	
	Too many heat sources in the room in cooling mode.	Use minimum heat sources and in a short time.
Too many people in the room in cooling mode.	Lower the temperature setting or change to "Medium" or "High".*	

* Regarding the fan speed control display on the remote controller, see page 13.

- If the P08 alarm and inspection mark are displayed on the remote controller and the fan automatically operates and does not stop even when you press ON/OFF operation button on remote controller, R32 refrigerant leakage detection sensor connected to the indoor unit has detected refrigerant leakage. In such a case, do not turn off the earth leakage circuit breaker, ventilate the room, and contact the service dealer immediately.

If your air conditioner does not work properly even after checking each item of "Before Requesting Services" and "Troubleshooting"

- Stop the operation immediately and turn the power off. Then contact your dealer and report the serial number and symptom. You also report if the inspection mark  and the letters E, F, H, L, P in combination with numbers appear on the LCD of the remote controller.
- Never repair the air conditioner by yourself since it is very dangerous for you to do so.

Connectable outdoor unit lineup

Europe

■ Refrigerant type : R410A

Outdoor unit type		4 HP	5 HP	6 HP	8 HP	10 HP
LE2	1-phase	U-4LE2E5	U-5LE2E5	U-6LE2E5	–	–
	3-phase	U-4LE2E8	U-5LE2E8	U-6LE2E8	–	–
LE1	3-phase	–	–	–	U-8LE1E8	U-10LE1E8
ME2	3-phase	–	–	–	U-8ME2E8	U-10ME2E8
MF3	3-phase	–	–	–	U-8MF3E8	U-10MF3E8
Outdoor unit type		12 HP	14 HP	16 HP	18 HP	20 HP
ME2	3-phase	U-12ME2E8	U-14ME2E8	U-16ME2E8	U-18ME2E8	U-20ME2E8
MF3	3-phase	U-12MF3E8	U-14MF3E8	U-16MF3E8	–	–

■ Refrigerant type : R32

Outdoor unit type		4 HP	5 HP	6 HP	8 HP	10 HP
LZ2	1-phase	U-4LZ2E5	U-5LZ2E5	U-6LZ2E5	–	–
	3-phase	U-4LZ2E8	U-5LZ2E8	U-6LZ2E8	U-8LZ2E8	U-10LZ2E8

Specifications

Indoor unit

Wall Mounted





Model Name		S-15MK2E5B	S-22MK2E5B	S-28MK2E5B	S-36MK2E5B	S-45MK2E5B	S-56MK2E5B	
Power source		220 - 230 - 240 V~ 50 - 60 Hz						
Cooling capacity	kW	1.5	2.2	2.8	3.6	4.5	5.6	
	BTU/h	5,100	7,500	9,600	12,300	15,400	19,100	
	Sensible kW	1.3	1.7	2.0	2.4	3.5	4.2	
	Latent kW	0.2	0.5	0.8	1.2	1.0	1.4	
Heating capacity	kW	1.7	2.5	3.2	4.2	5.0	6.3	
	BTU/h	5,800	8,500	10,900	14,300	17,100	21,500	
Cooling electric power input	kW	0.025	0.025	0.025	0.030	0.030	0.035	
Heating electric power input	kW	0.025	0.025	0.025	0.030	0.030	0.035	
Sound pressure level *	High	dB(A)	34	36	37	40	38	40
	Medium	dB(A)	32	33	34	36	35	37
	Low	dB(A)	29	29	29	29	33	35
Sound power level *	High	dB(A)	49	51	52	55	53	55
	Medium	dB(A)	47	48	49	51	50	52
	Low	dB(A)	44	44	44	44	48	50
Unit dimensions (H×W×D)	mm	290×870×214	290×870×214	290×870×214	290×870×214	302×1,120×236	302×1,120×236	
Net weight	kg	9	9	9	9	13	13	

Model Name		S-73MK2E5B	S-106MK2E5B	
Power source		220 - 230 - 240 V~ 50 - 60 Hz		
Cooling capacity	kW	7.3	10.6	
	BTU/h	24,900	36,200	
	Sensible kW	5.3	7.0	
	Latent kW	2.0	3.6	
Heating capacity	kW	8.0	11.4	
	BTU/h	27,300	38,900	
Cooling electric power input	kW	0.055	0.080	
Heating electric power input	kW	0.055	0.080	
Sound pressure level *	High	dB(A)	47	49
	Medium	dB(A)	44	46
	Low	dB(A)	40	42
Sound power level *	High	dB(A)	62	64
	Medium	dB(A)	59	61
	Low	dB(A)	55	57
Unit dimensions (H×W×D)	mm	302×1,120×236	302×1,120×236	
Net weight	kg	14	14	

Operation condition temperature range

- Cooling mode : 14°C~25°C WB
- Heating mode : 16°C~30°C DB

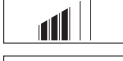
* Fan speed display on the remote controller

High	:		(CZ-RTC4),
			(CZ-RTC5B, CZ-RTC6*)
Medium	:		(CZ-RTC4),
			(CZ-RTC5B, CZ-RTC6*)
Low	:		(CZ-RTC4),
			(CZ-RTC5B, CZ-RTC6*)

Specifications

Outdoor unit

mini VRF (Type LZ2)

Model Name		U-4LZ2E5	U-5LZ2E5	U-6LZ2E5
Power source		220 - 230 - 240 V~ 50 Hz		
Cooling capacity	kW	12.1	14.0	15.5
Heating capacity	kW	12.5	16.0	16.5
Sound pressure level (Cooling / Heating)	dB(A)	52 / 54	53 / 56	54 / 56
Sound power level (Cooling / Heating)	dB(A)	69 / 72	70 / 74	72 / 75
Unit dimensions (H×W×D)	mm	996×980×370		
Net weight	kg	94	94	94

Model Name		U-4LZ2E8	U-5LZ2E8	U-6LZ2E8
Power source		380 - 400 - 415 V 3N~ 50 Hz		
Cooling capacity	kW	12.1	14.0	15.5
Heating capacity	kW	12.5	16.0	16.5
Sound pressure level (Cooling / Heating)	dB(A)	52 / 54	53 / 56	54 / 56
Sound power level (Cooling / Heating)	dB(A)	69 / 72	70 / 74	72 / 75
Unit dimensions (H×W×D)	mm	996×980×370		
Net weight	kg	94	94	94

Operation condition temperature range

- Cooling mode : -10°C~52°C DB
- Heating mode : -20°C~18°C WB

Rated conditions

Cooling : Indoor intake air temp. 27°C DB / 19°C WB. Outdoor intake air temp. 35°C DB.

Heating : Indoor intake air temp. 20°C DB. Outdoor intake air temp. 7°C DB / 6°C WB.

Model Name		U-8LZ2E8	U-10LZ2E8
Power source		380 - 400 - 415 V 3N~ 50 Hz	
Cooling capacity	kW	22.4	28.0
	BTU/h	76,500	95,600
Heating capacity	kW	25.0	28.0
	BTU/h	85,300	95,600
Sound pressure level	dB(A)	60	63
Sound power level	dB(A)	81	84
Unit dimensions (H×W×D)	mm	1,500×980×370	1,500×980×370
Net weight	kg	132	133

Operation condition temperature range

- Cooling mode : -10°C~52°C DB
- Heating mode : -20°C~18°C WB

Rated conditions

Cooling : Indoor intake air temp. 27°C DB / 19°C WB. Outdoor intake air temp. 35°C DB.

Heating : Indoor intake air temp. 20°C DB. Outdoor intake air temp. 7°C DB / 6°C WB.

mini VRF (Type LE1, LE2)

2WAY VRF (Type ME2)

3WAY VRF (Type MF3)

NOTE

Refer to the Operating Instructions attached to the outdoor unit.

Panasonic Corporation
<http://www.panasonic.com>

© Panasonic Corporation 2021

Authorised representative in EU
Panasonic Testing Centre
Panasonic Marketing Europe GmbH
Winsbergring 15, 22525 Hamburg, Germany

WEB-ACXF55-29100-EN
DC0121-0